

XH Series Specifications

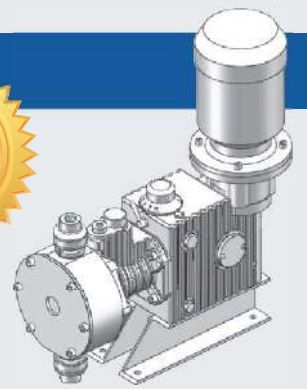

Type	Hydraulically Actuated Diaphragm
Flow control	STROKE control
Mode	Manual / Automatic (optional):- Designed to accept 4-20mA current signal through VFD.
Packing dimension	L - 680mm x B - 380mm x H - 820mm

Performance Parameter

Steady state accuracy	± 1%
Linearity	± 3%
Repeatability	± 3%
Turndown Ratio	10:1
Suction condition	Flooded suction

End Connections

Injection check	1½" NPT - M (Plastic) 1" NPT - (Metallic)
'Y' Strainer	1½" NPT - F

Material of Construction

Body	CI - IS 210 FG260	
Hydraulic Chamber & Motor Adaptor	CI - IS 210 FG260	
Base	MS fabricated	
Pump chamber	PP	SS 316
Suction check	PVC	SS 316
Delivery check	PVC	SS 316
'Y' Strainer	PP	SS 316
Injection check	PVC	SS 316
Diaphragm	Teflon - Nitrile Composite	
Ball check	Glass	SS 316

Pump Drive

Type	TEFC induction motor - - Class 'F' Insulation
Rating	415V, 3 phase, 1400 rpm, 50Hz, AC supply



Pump Dimensions

