

# XE Series Specifications

Type	Reciprocating diaphragm
Flow control	SPEED control
Mode	Manual / Automatic (optional):- Designed to accept 4-20mA current signal.
Packing dimension	L - 340mm x B - 320mm x H - 90mm

## Performance Parameter

Steady state accuracy	± 1%
Linearity	± 3%
Repeatability	± 3%
Tolerance	- 5% to + 10% on the rated flow @ rated back pressure
Suction Lift	1.5 m of water column

## End Connections

Injection check	1/2" NPT - M
-----------------	--------------

## Pump Drive

Type	Electromagnetic Power Drive
Power supply	230V, 1 phase, 50Hz, AC

## Material of Construction

Body	30% Glass filled Polypropylene (30% GFPP)	
Face plate	30% GFPP	
Splash guard	Polycarbonate	
Pump chamber	PP	SS 316
Suction check	PVC	SS 316
Delivery check	PVC	SS 316
Foot valve check	PVC	SS 316
Injection check	PVC	SS 316
Diaphragm	Teflon - Nitrile Composite	
Ball seat	Teflon	
Ball check	Ceramic	
Tubing	LDPE (3m) (OD - 9.5mm x ID - 6.35mm)	

## Pump Color

Body	Special Brown
Face plate	Bright Red
Splash guard	Transparent

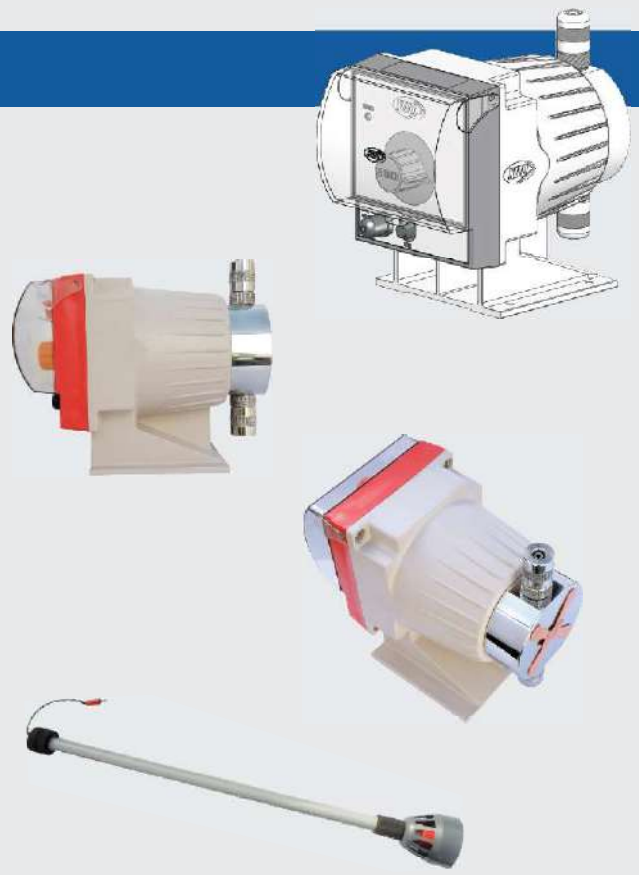

## Low Level Switch

Model	LX
Type	Magnetic float type

## Material of Construction

Float	Polyurethane (PU)
Guide tube	PVC
Float Guard	PVC

## Pump Dimensions

