

# **Pro**Minent **Meta Packed** **Plunger** **Metering** **Pumps**

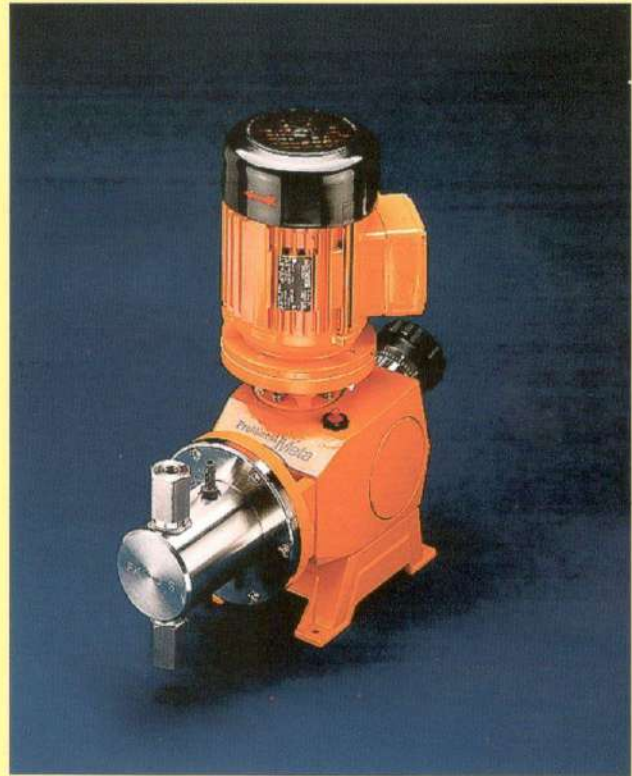

ProMinent Meta Packed Plunger Metering Pumps are compact, consume less power, offer high accuracy and reflect the high quality standards of ProMinent Metering Pumps.

ProMinent Meta Packed Plunger Metering Pumps are available up to a capacity of 49.3 l/hr at 52 bar. These Pumps can be offered with multiple heads. The Plunger of the pumps is made of high quality ceramic and liquid ends are made of Stainless Steel AISI 316.

The Pumps use worm gear reduction and the capacity of the motors used is 0.37 kW. These are suitable for a power supply of 415 Volts, 3 Phase, 50 c/s and can also be offered to suit other specifications.

The Pumps can be offered with motor speed controllers or servo controllers for stroke length adjustment wherever automatic control is needed.

Accessories like Pressure Relief Valve, Pulsation Dampner, Dosing Tank etc., can be offered with the Pump, as per the requirements. Complete Dosing Systems including Flow Meters, Tanks with Stirrers, Piping etc., mounted on skids can also be offered to suit any requirement.

Following information is needed to select a Metering Pump for an application:

- Chemical to be dosed
- Capacity in litres / hour
- Back Pressure

ProMinent Meta Pumps offer a highly reliable and proven solution for any metering requirement

## TECHNICAL DATA ProMinent Meta Plunger Metering Pumps

ProMinent Meta - MTKa : With motor 0.37 kW, 1440 rpm, 50 HZ, 415V

Pump Type	Pump capacity at Max. Back Pressure		Max. Stroke / Frequency		Suction Lift mWc	Admissible Pressure suction side bar	Connection size G-DN	Motor power output Kw	Shipping weight kg
	bar	l/hr	ml/stroke	strokes/min					
24006	240	6.1	1.42	72	4.0	120	1/4	0.37	20
22508	225	8.1	1.42	96	4.0	112.5	1/4	0.37	20
21610	216	10.2	1.42	120	4.0	108	1/4	0.37	20
21012	210	12.2	1.4	144	4.0	105	1/4	0.37	20
11313	113	13	3.01	72	4.0	56.5	1/4	0.37	20
10617	106	17.3	3.01	96	4.0	53	1/4	0.37	20
10222	102	21.7	3.01	120	4.0	51	1/4	0.37	20
9926	99	26	3.01	144	4.0	49.5	1/4	0.37	20
6025	60	24.6	5.71	72	4.0	30	3/8	0.37	20
5633	56	32.8	5.71	96	4.0	28	3/8	0.37	20
5441	54	41.1	5.71	120	4.0	27	3/8	0.37	20
5249	52	49.3	5.71	144	4.0	26	3/8	0.37	20

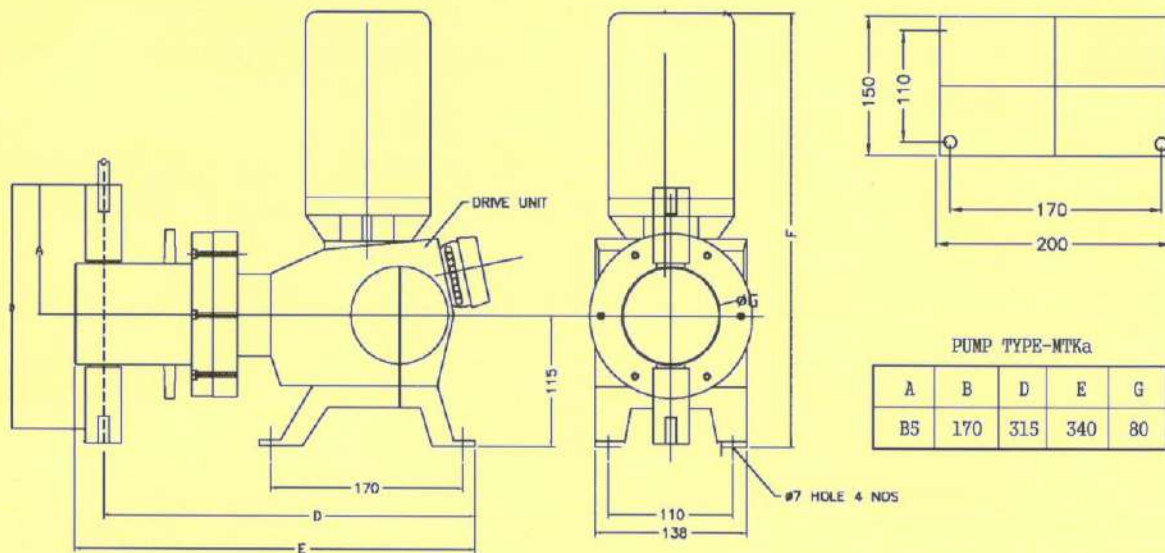

Heidelberg ProMinent Fluid Controls India Pvt. Ltd. is a fully owned subsidiary of ProMinent GmbH, Germany.

For further details please contact :

**Heidelberg ProMinent Fluid Controls India Pvt. Ltd.,**

(Fully Owned Subsidiary of ProMinent GmbH, Germany)

2/2, MES Road, Yeshwanthpur, Bangalore - 560 022

Tel: 00 91 80 23578872 / 73 / 74 / 23370730 / 23374954 Fax: 00 91 80 23477984 / 23573743

E-mail : prominent@hpfccindia.com Website: www.prominentindia.com



**ProMinent**