

ProMinent Plasma Motorised Metering Pumps



ProMinent Plasma Motorised Metering Pumps are compact, consume less power, offer high accuracy and reflect the high quality standards of ProMinent Metering Pumps.

ProMinent Plasma Diaphragm Pumps are available upto a capacity of 400 l/hr. These pumps are available in twelve different capacities.

The DEVELOPAN diaphragm of the Pump is made of high quality fabric reinforced EPDM with moulded in steel core and the media contacted side is coated with Teflon.

The Pumps use worm gear reduction and the capacity of the motors used is 0.18 or 0.37 kW depending on the model. These are suitable for a power supply of 415 Volts, 3 Phase, 50 c/s and can also be offered to suit other specifications.

The liquid ends can be offered in PVC(P), Poly Propylene (PP), Stainless Steel (S) or Teflon (T) depending upon the chemical.

The Pumps can be offered with motor speed controllers or servo controllers for stroke length adjustment wherever automatic control is needed.

Accessories like Pressure Relief Valve, Pulsation Dampner, Dosing Tank etc., can be offered with the Pump, as per the requirements.

Following information is needed to select a Metering Pump for an application:-

- Chemical to be dosed
- Capacity in litres / hour
- Back Pressure

ProMinent Plasma Pumps offer a highly reliable and proven solution for any metering requirement.

TECHNICAL DATA

ProMinent Plasma Diaphragm type Metering Pumps

ProMinent Plasma PSMa : With motor 0.18 kW / 0.37 kW, 1440 rpm, 415 V, 50 c/s								
Pump Type	Pump Capacity Max. Back Pressure		Max. Stroke		Suction Lift	Connection Size	Motor Rating	Shipping Weight
	bar	l/hr	ml/stroke	strokes/min	mWC	G-DN	kW	Kg (PP/SS)
10010	10	10	1.4	115	3	8 x 5 m.m	0.18	11 / 12
10015	10	15	1.7	150	3	8 x 5 m.m	0.18	11 / 12
10020	10	20	3.6	115	3	1 1/4" - 20	0.18	11 / 12
10030	10	30	3.9	150	3	1 1/4" - 20	0.18	11 / 12
05050	5	50	7.2	115	3	1 1/4" - 20	0.18	12.1 / 14.5
05065	5	65	7.2	150	3	1 1/4" - 20	0.18	12.1 / 14.5
05090	5	90	13.0	115	3	1 1/4" - 20	0.18	12.1 / 14.5
05120	5	120	13.3	150	3	1 1/4" - 20	0.18	12.1 / 14.5
05200	5	200	29.0	115	3	1 1/4" - 20	0.18	12.1 / 14.5
05260	5	260	29.0	150	3	1 1/4" - 20	0.18	12.1 / 14.5
05300	5	300	43.5	115	3	1 1/4" - 20	0.37	14.5 / 16.9
05400	5	400	44.4	150	3	1 1/4" - 20	0.37	14.5 / 16.9

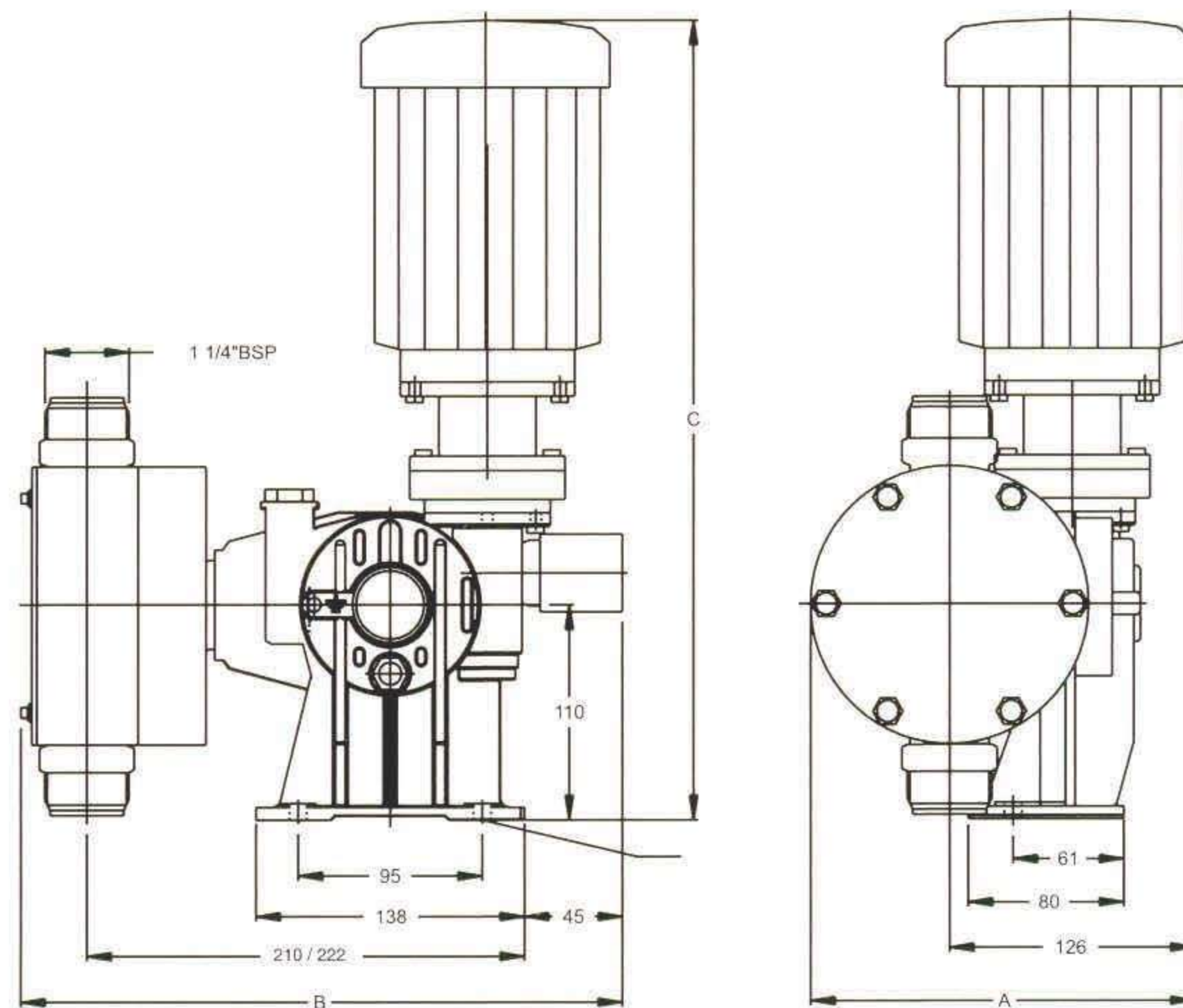

DIMENSIONS in mm

Pump Type	A	B	C
10010, 10015, 10020, 10030	198	280	352
05050, 05065, 05090 05120, 05200, 05260 05300, 05400	198	310	352

Heidelberg ProMinent Fluid Controls India Pvt. Ltd. is a fully owned subsidiary of ProMinent Dosiertechnik GmbH, Germany.



For further details please contact :

Heidelberg ProMinent Fluid Controls India Pvt. Ltd.,

(Fully Owned Subsidiary of ProMinent Dosiertechnik GmbH, Germany)

2/2, MES Road, Yeshwanthpur, Bangalore - 560 022

Tel: 00 91 80 23578872 / 73 / 74, 23370730, 23374954 Fax: 00 91 80 23477984, 23573743

E-mail : prominent@hpfccindia.com Website: www.prominentindia.com