

Dosing pump m-Roy Series – A, B, H & P

- Maximum Flow rate: 94 l/h • Maximum Pressure: 126 kg/cm²g • hydraulically actuated diaphragm
- Conforms to API-675 Standard

Technical characteristics

- Flow rate up to:
 - 94 l/h for m-Roy A with metallic liquid end @ 7 kg/cm² g
 - 9.5l/h for m-Roy A with metallic liquid end @ 126 kg/cm² g
- Pressure up to:
 - 126 kg/cm² g for m-Roy with metallic liquid end
 - 10 kg/cm² g for m-Roy with plastic liquid end
- Maximum temperature of pumped liquid:
 - +90 °C for metallic liquid end
 - +45 °C for plastic liquid end
- Manual or automatic flow control, adjustment of flow rate while running: from 0 to 100%
- High-efficiency, hydraulically actuated PTFE diaphragm for long life and high precision check valves for reliable sealing
- Steady state accuracy ±1% of the rated capacity
- Repeatability ±3% of the rated capacity
- Turndown ratio 10:1
- Maximum suction pressure condition: 6 kg/cm² g
- Adjustable internal hydraulic relief valve for pump protection
- Diaphragm Rupture Detection System (DRDS)

Options:

- Variable speed drive, Electronic capacity controller, Pneumatic actuator / ACC
- DRDS with pressure gauge is standard. Pressure switch/transmitter is optional.

Characteristics of motors

Standard Motor Data:

- m-Roy A & P Model: 0.5HP TEFC Enclosure
- m-Roy B & all model: 1.0HP TEFC Enclosure
- Power Supply: 415V – 50 Hz – 3 phase
- Degree of protection: IP 55, class F
- Motor Speed: 1440 rpm, IE2

Options:

- Flame/Explosion proof motors

Accessories

To meet your installation needs a large range of accessories are available on request (Pulsation dampeners, safety and back pressure valves), consult us.



m-Roy - Metallic Liquid End

Liquid end construction

Components	Materials			
Model	m-Roy A, H, B & P (Metallic Liquid End)	m-Roy A & H (Plastic Liquid End)		
Head	CF8M	PP	PVC	PVDF
Cartridge/Suction & Discharge valve	SS-316	PVC	PVC	PVDF
Ball	SS-316	CERAMIC	CERAMIC	CERAMIC
Seat	SS-316	TEFLON	TEFLON	TEFLON
Contour plate	SS-316	SS-316	SS-316	SS-316
Diaphragm	PTFE	PTFE	PTFE	PTFE

Note: Alloy20, SS316L, SS304 are the MOC options available for liquid end. Contact company for more details.

Performances m-Roy A (Metallic Liquid End)

MODEL	PLUNGER DIAMETER	GEAR RATIO	SPM	FLOW (LPH) Vs PRESSURE (Kg/Cm ² (g)) @ 100% STROKE										Viscosity in CPS
				7 Kg /Cm ²	10 Kg /Cm ²	14 Kg /Cm ²	21 Kg /Cm ²	24.5 Kg /Cm ²	28 Kg /Cm ²	56 Kg /Cm ²	84 Kg /Cm ²	105 Kg /Cm ²	126 Kg /Cm ²	
MRA 11 H	7/16"	77:1	19	1.7	1.7	1.7	1.7	1.7	1.7	1.5	1.3	1.3	1	2400
MRA 12 H	7/16"	48:1	30	2.3	2.0	2.0	2.0	2.0	2.0	1.8	1.8	1.8	1.7	1460
MRA 13 H	7/16"	24:1	60	5.2	5.2	5.2	5.0	5.0	5.0	4.5	4.2	4	3.6	460
MRA 14 H	7/16"	15:1	96	8.5	8.3	8.3	8.3	8.0	8.0	7.7	7	6.5	6	250
MRA 15 H	7/16"	9.5:1	152	13.5	12.5	12.5	12.5	12.5	12.5	12.5	11	10	9.5	90
MRA 32	1-1/16"	48:1	30	19	18.5	18.5	17.8	17.0	--	--	--	--	--	130
MRA 33	1-1/16"	24:1	60	38.5	38.0	38.0	36.0	35.0	--	--	--	--	--	60
MRA 34	1-1/16"	15:1	96	60.8	60.5	60.0	58.0	57.0	--	--	--	--	--	30
MRA 35	1-1/16"	9.5:1	152	94	92.5	91.0	--	--	--	--	--	--	--	90

Note: Plastic liquid ends can be offered in specific cases for a maximum pressure of 10Kg/cm²g. Contact factory for more details.

Performances m-Roy A (Metallic Liquid End with DRDS)

MODEL	PLUNGER DIAMETER	GEAR RATIO	SPM	FLOW (LPH) Vs PRESSURE (Kg/Cm ² (g)) @ 100% STROKE										Viscosity in CPS
				7 Kg /Cm ²	10 Kg /Cm ²	14 Kg /Cm ²	21 Kg /Cm ²	24.5 Kg /Cm ²	28 Kg /Cm ²	56 Kg /Cm ²	84 Kg /Cm ²	105 Kg /Cm ²	126 Kg /Cm ²	
MRA 11D	7/16"	77:1	19	1.5	1.5	1.5	1.5	1.5	--	--	--	--	--	2400
MRA 12D	7/16"	48:1	30	2.3	1.9	1.9	1.9	1.9	--	--	--	--	--	1460
MRA 13D	7/16"	24:1	60	4.9	4.9	4.9	4.8	4.8	--	--	--	--	--	460
MRA 14D	7/16"	15:1	96	8.1	7.9	7.9	7.9	7.6	--	--	--	--	--	250
MRA 23D	5/8"	24:1	60	11.2	10.9	10.9	10.5	10.5	--	--	--	--	--	220
MRA 32D	1-1/16"	48:1	30	18.1	17.6	17.6	16.9	16.2	--	--	--	--	--	130
MRA 33D	1-1/16"	24:1	60	36.6	36.1	36.1	34.2	33.3	--	--	--	--	--	60
MRA 34D	1-1/16"	15:1	96	57.8	57.5	57	55.1	54.2	--	--	--	--	--	30
MRA 35D	1-1/16"	9.5:1	152	89.3	87.9	86.5	--	--	--	--	--	--	--	90

Note: Plastic liquid ends can be offered in specific cases for a maximum pressure of 10Kg/cm²g. Contact factory for more details.

Performances m-Roy P (Metallic Liquid End)

MODEL	PLUNGER DIAMETER	GEAR RATIO	SPM	FLOW (LPH) Vs PRESSURE (Kg/Cm ² (g)) @ 100% STROKE										Viscosity in CPS
				7 Kg /Cm ²	10 Kg /Cm ²	14 Kg /Cm ²	21 Kg /Cm ²	24.5 Kg /Cm ²	28 Kg /Cm ²	56 Kg /Cm ²	84 Kg /Cm ²	105 Kg /Cm ²	126 Kg /Cm ²	
MRP 11	7/16"	77:1	19	1.5	1.5	1.5	1.5	1.5	--	--	--	--	--	12200
MRP 12	7/16"	48:1	30	2	1.8	1.8	1.8	1.8	--	--	--	--	--	7500
MRP 13	7/16"	24:1	60	4.5	4.5	4.5	4.0	4.0	--	--	--	--	--	4000
MRP 14	7/16"	15:1	96	7.5	7	7.0	7.0	6.5	--	--	--	--	--	2000
MRP 23	5/8"	24:1	60	10	9.5	9.5	9.0	9.0	--	--	--	--	--	2500
MRP 32	1-1/16"	48:1	30	16	15.5	15.5	15.2	14	--	--	--	--	--	1000
MRP 33	1-1/16"	24:1	60	32.5	32	32	30	29	--	--	--	--	--	500
MRP 34	1-1/16"	15:1	96	52	51	51	49	48	--	--	--	--	--	300

Note: Plastic liquid ends can be offered in specific cases for a maximum pressure of 10Kg/cm²g. Contact factory for more details.

Performances m-Roy P (Metallic Liquid End with DRDS)

MODEL	PLUNGER DIAMETER	GEAR RATIO	SPM	FLOW (LPH) Vs PRESSURE (Kg/Cm ² (g)) @ 100% STROKE										Viscosity in CPS
				7 Kg /Cm ²	10 Kg /Cm ²	14 Kg /Cm ²	21 Kg /Cm ²	24.5 Kg /Cm ²	28 Kg /Cm ²	56 Kg /Cm ²	84 Kg /Cm ²	105 Kg /Cm ²	126 Kg /Cm ²	
MRP 11D	7/16"	77:1	19	1.4	1.4	1.4	1.4	1.4	--	--	--	--	--	12200
MRP 12D	7/16"	48:1	30	1.9	1.7	1.7	1.7	1.7	--	--	--	--	--	7500
MRP 13D	7/16"	24:1	60	4.3	4.3	4.3	3.8	3.8	--	--	--	--	--	4000
MRP 14D	7/16"	15:1	96	7.1	6.7	6.7	6.7	6.2	--	--	--	--	--	2000
MRP 23D	5/8"	24:1	60	9.5	9	9.0	8.6	8.6	--	--	--	--	--	2500
MRP 32D	1-1/16"	48:1	30	15.2	14.7	14.7	14.5	13.3	--	--	--	--	--	1000
MRP 33D	1-1/16"	24:1	60	30.9	30.4	30.4	28.5	27.6	--	--	--	--	--	500
MRP 34D	1-1/16"	15:1	96	49.4	48.5	48.5	46.6	45.6	--	--	--	--	--	300

Note: Plastic liquid ends can be offered in specific cases for a maximum pressure of 10Kg/cm²g. Contact factory for more details.

Performances m-Roy B (Metallic Liquid End)

MODEL	PLUNGER DIAMETER (mm)	GEAR RATIO	SPM	FLOW (LPH) Vs PRESSURE (Kg/Cm ² (g)) @ 100% STROKE										Viscosity in CPS
				7 Kg /Cm ²	10 Kg /Cm ²	28 Kg /Cm ²	41 Kg /Cm ²	65 Kg /Cm ²	83 Kg /Cm ²	100 Kg /Cm ²	--	--	--	
MRB 11	15	25:1	58	18.0	17.5	17.0	16.5	16.0	15.0	14.0	--	--	--	130
MRB 12	15	15:1	96	27.5	27.0	26.5	26.0	25.0	24.5	24.0	--	--	--	59
MRB 13	15	10:1	144	45.0	44.0	42.0	40.0	39.0	38.0	36.0	--	--	--	39
MRB 21	22	25:1	58	34.0	33.0	32.0	31.0	30.0	--	--	--	--	--	325
MRB 22	22	15:1	96	65.5	65.0	60.0	57.0	50.0	--	--	--	--	--	143
MRB 23	22	10:1	144	88.0	87.0	83.0	80.0	75.0	--	--	--	--	--	94

Note: Plastic liquid ends can be offered in specific cases for a maximum pressure of 10Kg/cm²g. Contact factory for more details.

Performances m-Roy B (Metallic Liquid End with DRDS)

MODEL	PLUNGER DIAMETER (mm)	GEAR RATIO	SPM	FLOW (LPH) Vs PRESSURE (Kg/Cm ² (g)) @ 100% STROKE										Viscosity in CPS
				7 Kg /Cm ²	10 Kg /Cm ²	28 Kg /Cm ²	41 Kg /Cm ²	65 Kg /Cm ²	--	--	--	--	--	
MRB 21D	22	25:1	58	32.0	31.0	30.0	27.0	28.0	--	--	--	--	--	325
MRB 22D	22	15:1	96	62.0	61.0	57.0	57.0	47.0	--	--	--	--	--	143
MRB 23D	22	10:1	144	83.0	82.0	78.0	76.0	77.0	--	--	--	--	--	94

Note: Plastic liquid ends can be offered in specific cases for a maximum pressure of 10Kg/cm²g. Contact factory for more details.

Performances m-Roy A (Metallic Liquid End with DRDS)

m-ROY A WITH PLASTIC LIQUID ENDS				m-ROY A WITH PLASTIC LIQUID ENDS & DRDS			
MODEL	SPM	FLOW (LPH) Vs PRESSURE (Kg/Cm ² (g)) @ 100% STROKE		MODEL	SPM	FLOW (LPH) Vs PRESSURE (Kg/Cm ² (g)) @ 100% STROKE	
		7 Kg/Cm ² (g)	10 Kg/Cm ² (g)			7 Kg/Cm ² (g)	10 Kg/Cm ² (g)
MRA 11 H	19	1.7	1.7	MRA 11D	19	1.5	1.5
MRA 12 H	30	2.3	2	MRA 12D	30	2.3	1.9
MRA 13 H	60	5.2	5.2	MRA 13D	60	4.9	4.9
MRA 14 H	96	8.5	8.3	MRA 14D	90	8.1	7.9
MRA 15 H	152	13.5	12.5	MRA 23D	60	11.2	10.9
MRA 32	30	19	18.5	MRA 32D	30	18.1	17.6
MRA 33	60	38.5	38	MRA 33D	60	36.6	36.1
MRA 34	96	60.8	60.5	MRA 34D	96	57.8	57.5
MRA 35	152	94	92.5	MRA 35D	152	89.3	87.9

Note: Plastic liquid ends can be offered in specific cases for a maximum pressure of 10Kg/cm²g. Contact factory for more details.

Dimensions

General Arrangement Of mROY-A & H Series Pump (Metallic Liquid End)

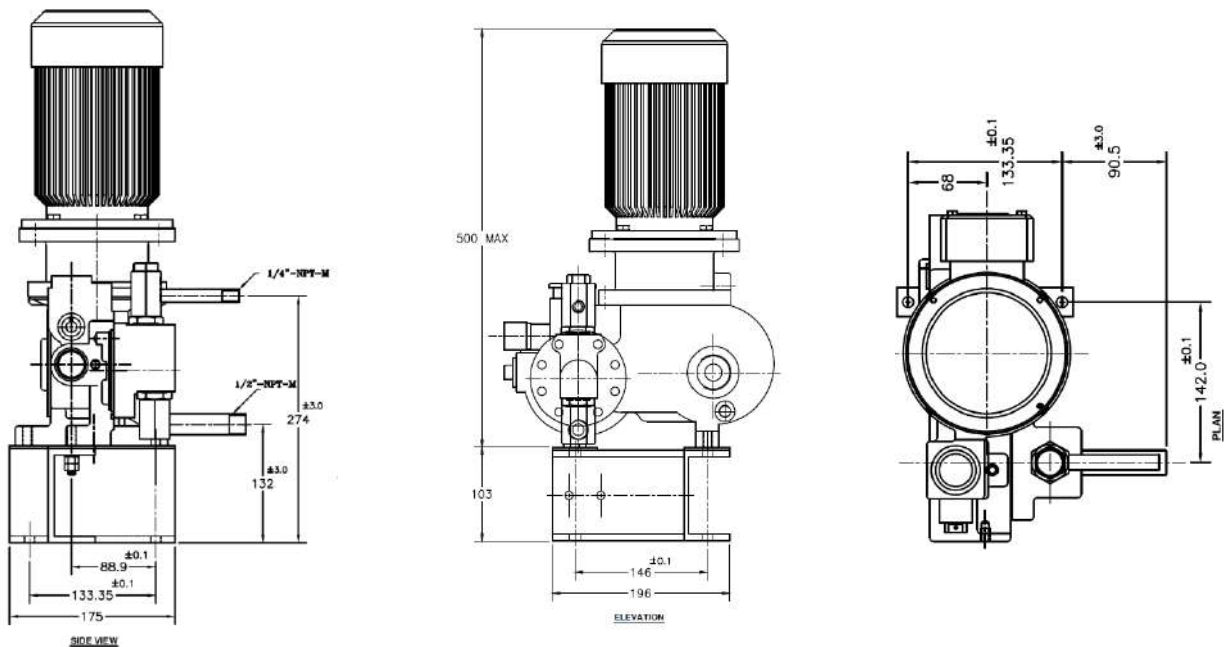

General Arrangement Of mROY-A Series Pump (Metallic Liquid End)

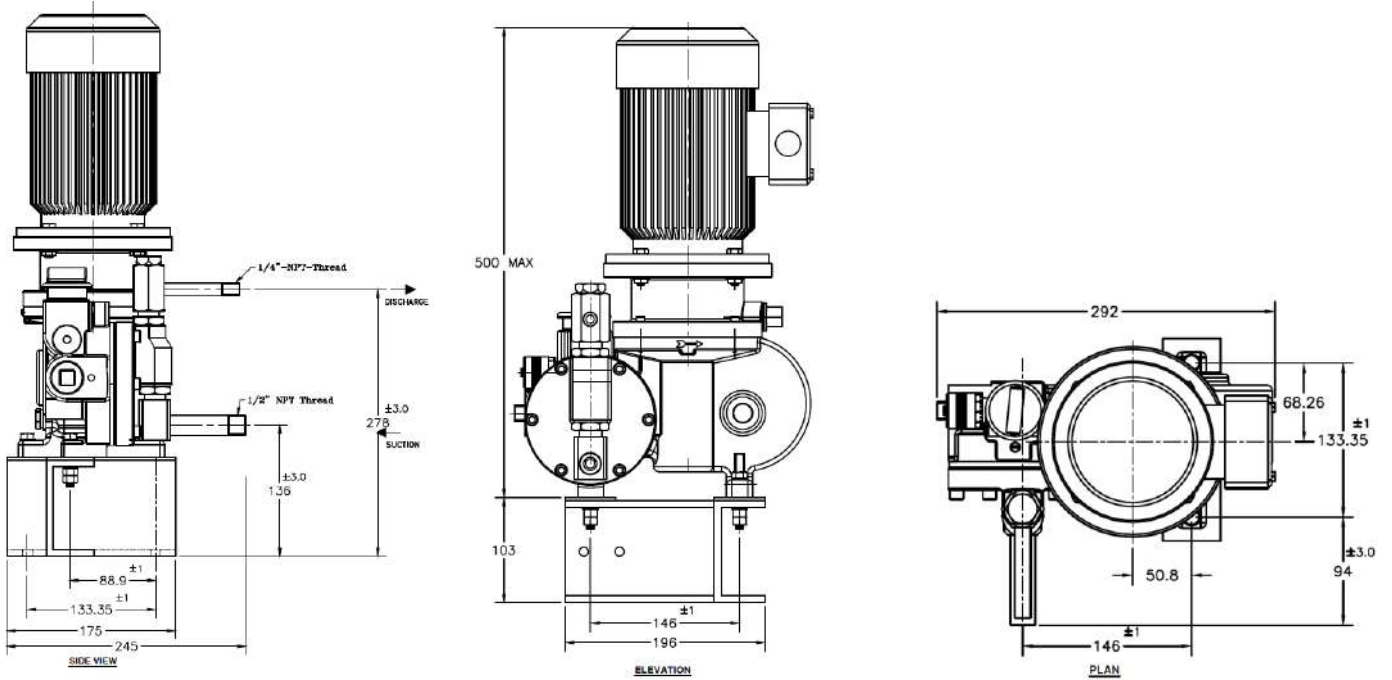

General Arrangement Of mROY-A Series Pump (Plastic Liquid End)

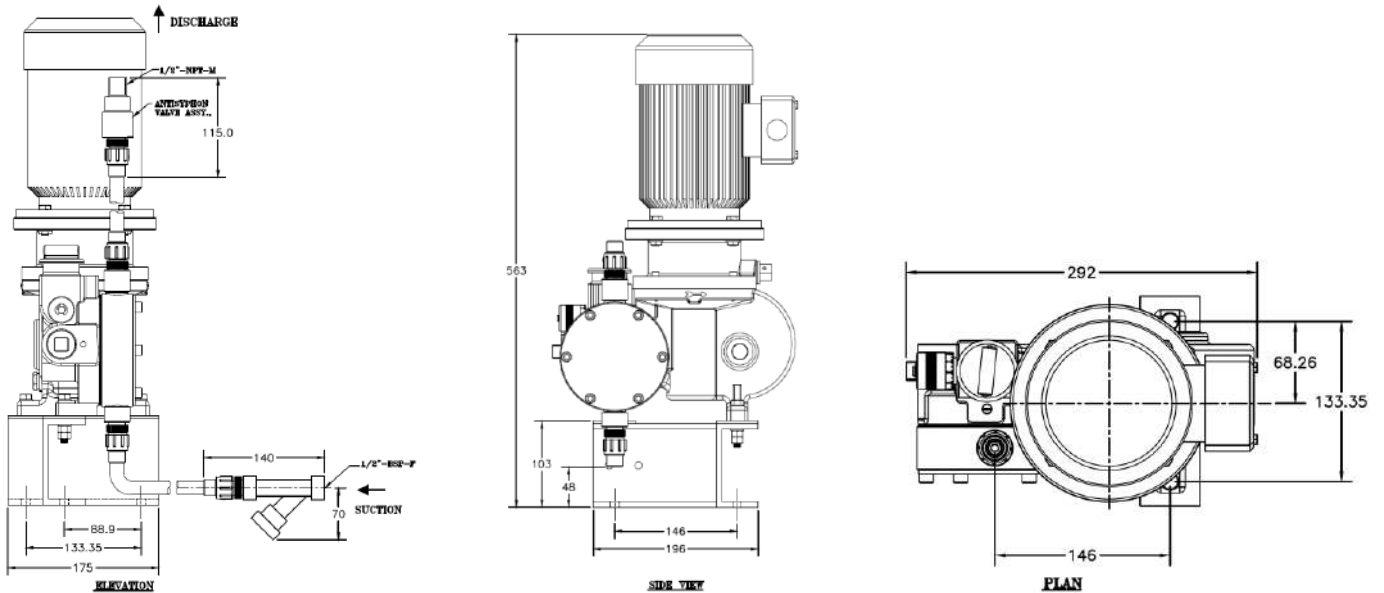

General Arrangement Of mROY-B Series Pump (Metallic Liquid End)

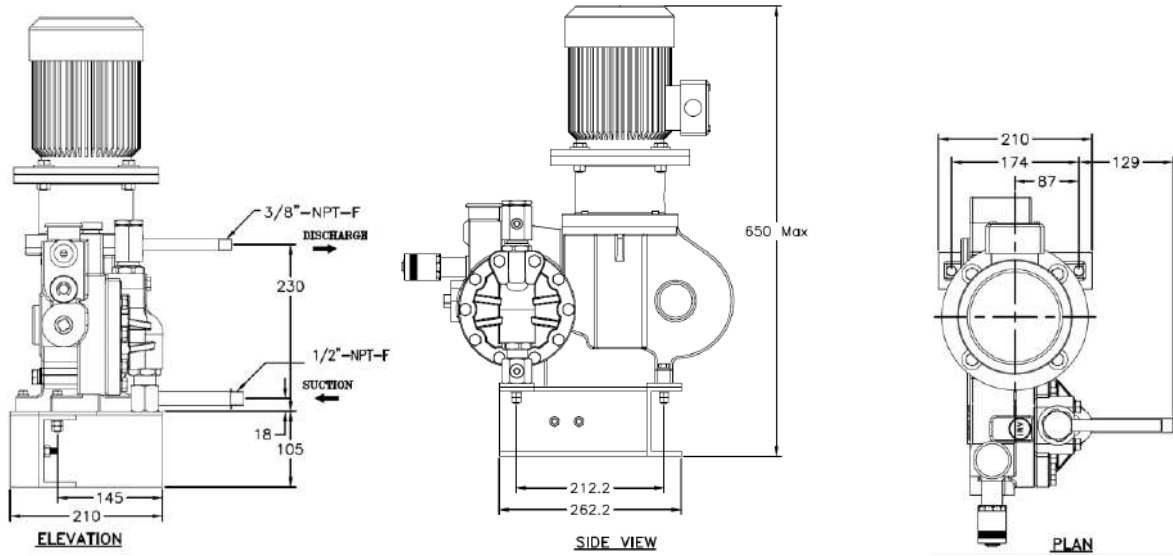

*Any changes in this catalogue applicable without prior Information



Plot No: 45/1, 8th Avenue, Domestic Tariff Area,
Mahindra World City, Chengalpet District,
Chengalpet – 603004, Tamilnadu, India.
Tel Ph. No: +91-44-71113111
mr-sales@miltonroy.com | www.miltonroyindia.com

